

Connection hoses and cables	
Water hose:	✓
Waste water hose:	✗
Electric cable:	✓ 2x

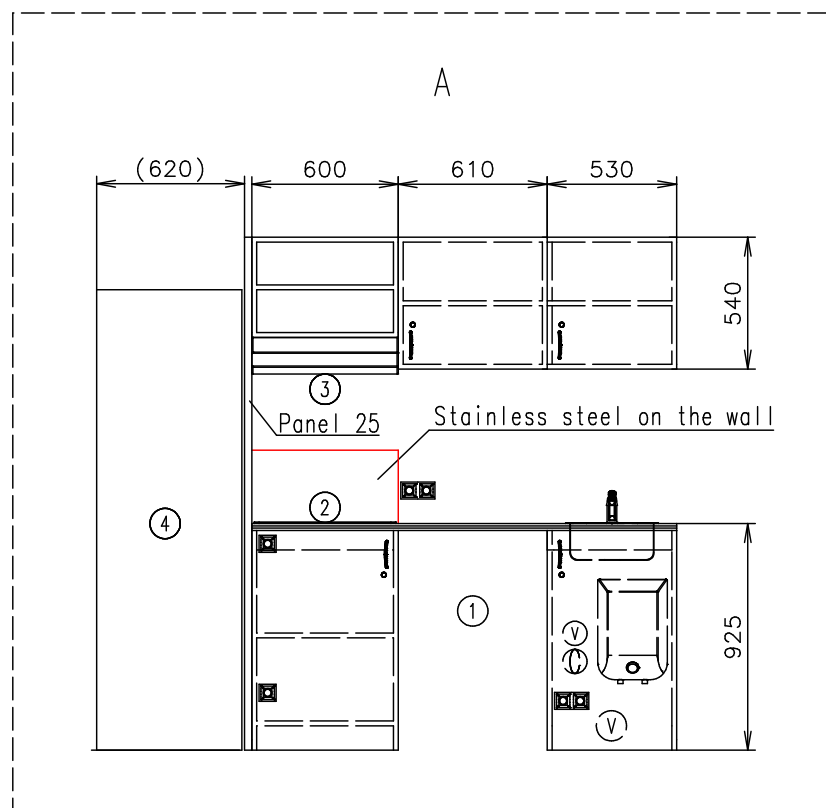

(Cabling and piping is not shown on the 3D views and drawings)

Notes:

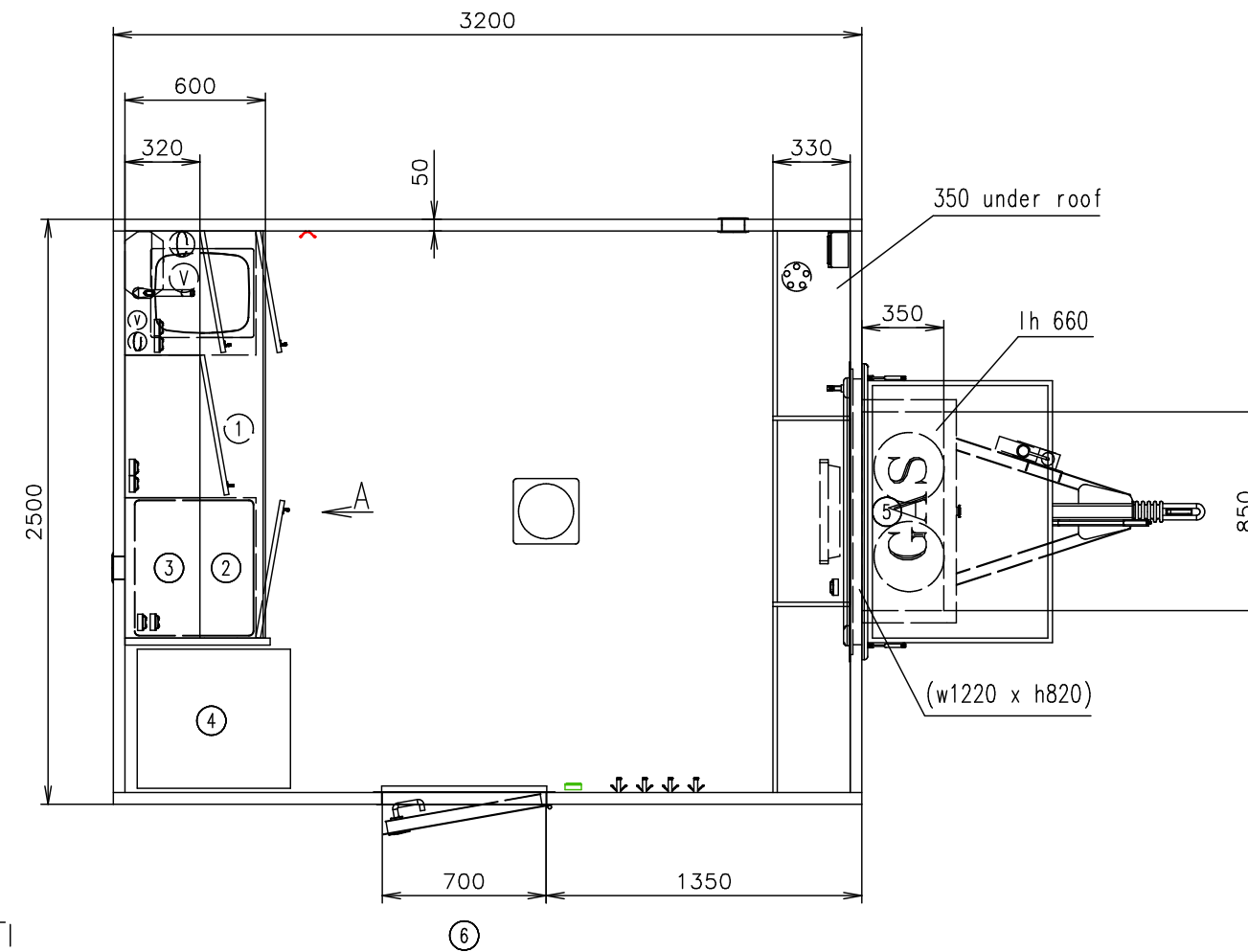



Interior height:	2100 mm	Total weight:	1300 kg
Color:	RAL 9010	Tare weight-estimate:	1000 kg
Floor:	PVC gray	Centre of wheels from rear side:	1300 mm
Date:	12.11.2018	Wheels:	165 R13C

EUROWAGON

Drawing number:
3146-32-1_1/2 (Maas)

Connection hoses and cables	
Water hose:	✓
Waste water hose:	✗
Electric cable:	✓ 2x

- Ⓥ Water connection 3/4" (through the floor)
- ⊙ 2x electric connection (on the chassis) (230V-16A) (1x power point for washing machine) (1x the rest)
- ⓪ Effluent connection ø40 (through floor)
- Ⓜ Power point
- Ⓛ Light switch
- Ⓜ Double power point
- Ⓛ Switch board (under the shelf)
- ⓪ LED droplight
- Ⓛ Kitchen sink Alveus Basic 10 + standard water tap
- Ⓛ Hot water boiler Wterm FHN (5l)

-  Window opening inside (870 over floor) + shutter
-  Ventilation ø120
-  Shelf
-  Clothes hanger
-  Clothes hanger
- ① Place for wasing-machine
- ② Gas cooker – 4 hotplate
- ③ Cooker hood
- ④ Fridge with freezer Whirlpool BLF 8121 W
- ⑤ GAS regulator
- ⑥ Standard free standing stairs

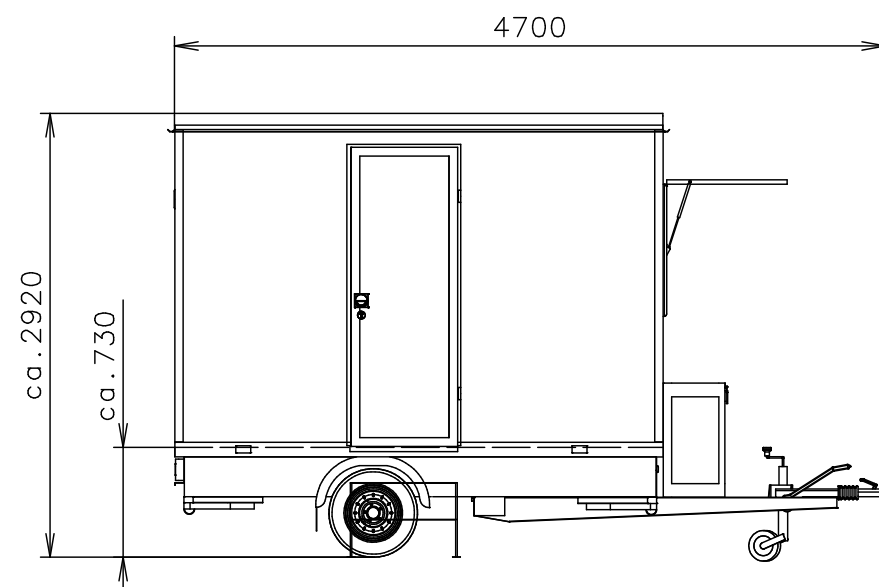

(Cabling and piping is not shown on the 3D views and drawings)

Notes:

Interior height:	2100 mm	Total weight:	1300 kg
Color:	RAL 9010	Tare weight-estimate:	1000 kg
Floor:	PVC gray	Centre of wheels from rear side:	1300 mm
Date:	12.11.2018	Wheels:	165 R13C

EUROWAGON

Drawing number:
3146-32-1_2/2 (Maas)