

Connection hoses and cables	
Water hose:	✓
Waste water hose:	✓
Electric cable:	✓

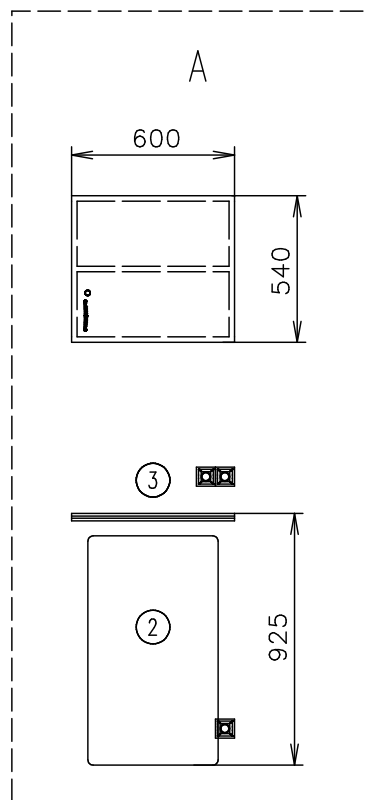
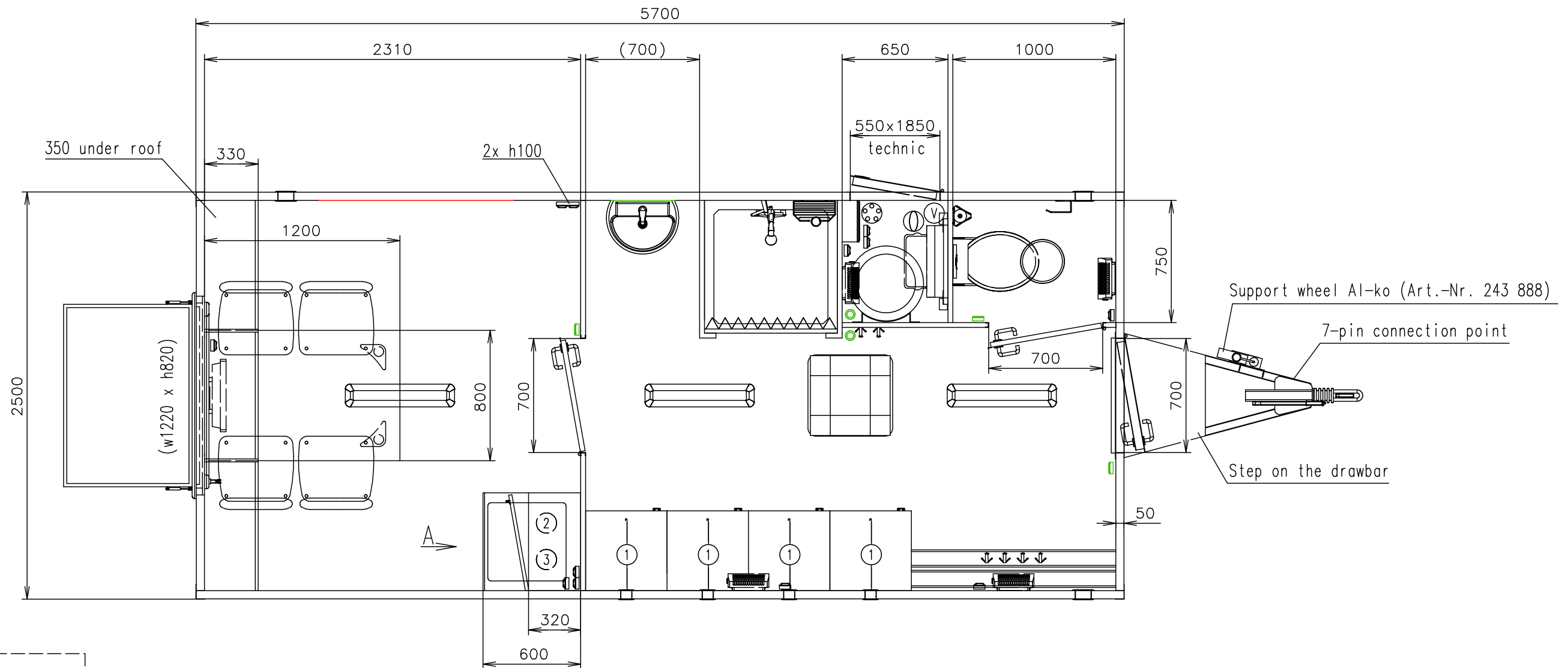

(Cabling and piping is not shown on the 3D views and drawings)

Notes: Folio ?

Interior height:	2100 mm	Total weight:	2000 kg
Color:	RAL 9010 + folio	Tare weight-estimate:	1700 kg
Floor:	PVC gray	Centre of wheels from rear side:	2790 mm
Date:	25.8.2017	Wheels:	155 R13

EUROWAGON

Drawing number:
2721-57-3_1/2

Connection hoses and cables	
Water hose:	✓
Waste water hose:	✓
Electric cable:	✓

- Ⓟ Water connection 3/4" (through the floor)
- Ⓢ Electric connection (through the floor) (380V-16A)
- Ⓣ Effluent connection 1"
- Ⓤ Power point
- Ⓥ Double power point
- Ⓦ Light switch
- Ⓧ Switch board (900 over floor)
- Ⓨ Droplight
- Ⓩ Droplight
- ⓐ Heating (500W)
- ⓑ Heating (750W)
- ⓓ Floor drain hole
- ⓔ Shower (800x800) Cola
- ⓕ Wash-basin Kolo (450x330) + standard water tap
- ⓖ Hanging toilet + pump Setsan
- ⓗ Hot water boiler (30 l)
- Ⓢ Window opening inside + shutter (870 over floor)
- Ⓣ Roof window Dometic (400x400)
- Ⓤ Chair
- Ⓥ Desk permanent fixed (1200x800)
- Ⓦ Shelf
- Ⓧ Wooden bench
- Ⓨ Ventilation ø120
- Ⓩ Brush toilet
- ⓐ Toilet paper holder
- ⓑ Shelf steel
- ⓓ Shower curtain
- ⓔ Clothes hanger
- ⓕ Mirror (400x400)
- ⓖ Cork noticeboard (1200x800)
- ⓗ ① Cupboard (sheet metal) (500x500x1700)
- Ⓢ ② Fridge
- Ⓣ ③ Coffee machine

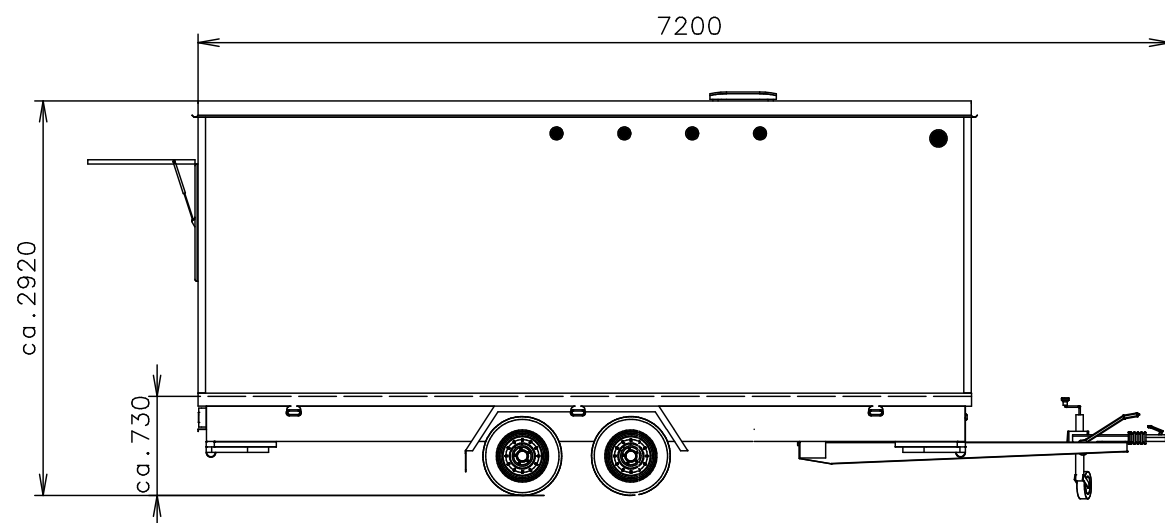

(Cabling and piping is not shown on the 3D views and drawings)

Notes: Folio ?

Interior height:	2100 mm	Total weight:	2000 kg
Color:	RAL 9010 + folio	Tare weight-estimate:	1700 kg
Floor:	PVC gray	Centre of wheels from rear side:	2790 mm
Date:	25.8.2017	Wheels:	155 R13

EUROWAGON

Drawing number:

2721-57-3_2/2